

ETSI EN 300 392-11-12 V1.1.2 (2003-05)

European Standard (Telecommunications series)

**Terrestrial Trunked Radio (TETRA);
Voice plus Data (V+D);
Part 11: Supplementary services stage 2;
Sub-part 12: Call Hold (HOLD)**



Reference

REN/TETRA-03111-11-12

Keywords

data, HOLD, radio, speech, stage 2,
supplementary service, TETRA, V+D

ETSI

650 Route des Lucioles
F-06921 Sophia Antipolis Cedex - FRANCE

Tel.: +33 4 92 94 42 00 Fax: +33 4 93 65 47 16

Siret N° 348 623 562 00017 - NAF 742 C
Association à but non lucratif enregistrée à la
Sous-Préfecture de Grasse (06) N° 7803/88

Important notice

Individual copies of the present document can be downloaded from:

<http://www.etsi.org>

The present document may be made available in more than one electronic version or in print. In any case of existing or perceived difference in contents between such versions, the reference version is the Portable Document Format (PDF). In case of dispute, the reference shall be the printing on ETSI printers of the PDF version kept on a specific network drive within ETSI Secretariat.

Users of the present document should be aware that the document may be subject to revision or change of status. Information on the current status of this and other ETSI documents is available at

<http://portal.etsi.org/tb/status/status.asp>

If you find errors in the present document, send your comment to:

editor@etsi.org

Copyright Notification

No part may be reproduced except as authorized by written permission.
The copyright and the foregoing restriction extend to reproduction in all media.

© European Telecommunications Standards Institute 2003.
All rights reserved.

DECT™, PLUGTESTS™ and UMTS™ are Trade Marks of ETSI registered for the benefit of its Members.
TIPHON™ and the TIPHON logo are Trade Marks currently being registered by ETSI for the benefit of its Members.
3GPP™ is a Trade Mark of ETSI registered for the benefit of its Members and of the 3GPP Organizational Partners.

Contents

Intellectual Property Rights	4
Foreword.....	4
1 Scope	6
2 References	6
3 Definitions and abbreviations.....	7
3.1 Definitions	7
3.2 Abbreviations	7
4 Functional model.....	7
4.1 Functional model description	7
4.2 Description of functional entities	8
4.2.1 Served user functional entity, FE1	8
4.2.2 Served user SwMI functional entity, FE21	9
4.2.3 Served user new SwMI functional entity, FE21'.....	9
4.2.4 Affected user SwMI functional entity, FE25	9
4.2.5 Affected user functional entity, FE5	9
4.3 Relationship of functional model to basic call functional model	9
5 Information flows	10
5.1 Definition of information flows.....	10
5.1.1 INFORM 1	10
5.1.2 INFORM 2.....	10
5.1.3 INFORM 3	11
5.1.4 INTERROGATE	11
5.1.5 INTERROGATE ACK	11
5.1.6 INVOKE.....	12
5.1.7 INVOKE ACK.....	12
5.1.8 rd_LOCATION CHANGE	12
5.1.9 re_LOCATION CHANGE	13
5.1.10 RETRIEVE	14
5.1.11 RETRIEVE ACK.....	14
5.2 Relationship of information flows to basic call information flows	15
5.3 Service primitives.....	16
5.4 Examples of information flow sequences.....	16
5.4.1 Interrogation	16
5.4.2 Invocation and operation	17
5.4.2.1 Successful invocation.....	17
5.4.2.2 Successful retrieval of call on hold	17
5.4.2.3 Invocation failure	18
5.4.2.4 Retrieval failure.....	18
5.4.2.5 Migration of served user with calls on hold	19
6 FE actions	20
6.1 Functional Entity actions of FE1	20
6.2 Functional Entity actions of FE21	21
6.3 Functional Entity actions of FE21'	22
6.4 Functional Entity actions of FE25	22
6.5 Functional Entity actions of FE5	22
7 Allocation of functional entities to physical equipment.....	23
8 Interworking considerations	23
History	24

Intellectual Property Rights

IPRs essential or potentially essential to the present document may have been declared to ETSI. The information pertaining to these essential IPRs, if any, is publicly available for **ETSI members and non-members**, and can be found in ETSI SR 000 314: *"Intellectual Property Rights (IPRs); Essential, or potentially Essential, IPRs notified to ETSI in respect of ETSI standards"*, which is available from the ETSI Secretariat. Latest updates are available on the ETSI Web server (<http://webapp.etsi.org/IPR/home.asp>).

All published ETSI deliverables shall include information which directs the reader to the above source of information.

Foreword

This European Standard (Telecommunications series) has been produced by ETSI Project Terrestrial Trunked Radio (TETRA).

The present document is part 11, sub-part 12 of a multi-part deliverable covering the Voice plus Data (V+D), as identified below:

- EN 300 392-1: "General network design";
- EN 300 392-2: "Air Interface (AI)";
- EN 300 392-3: "Interworking at the Inter-System Interface (ISI)";
- ETS 300 392-4: "Gateways basic operation";
- EN 300 392-5: "Peripheral Equipment Interface (PEI)";
- EN 300 392-7: "Security";
- EN 300 392-9: "General requirements for supplementary services";
- EN 300 392-10: "Supplementary services stage 1";

EN 300 392-11: "Supplementary services stage 2";

- ETS 300 392-11-1: "Call Identification (CI)";
- ETS 300 392-11-2: "Call Report (CR)";
- ETS 300 392-11-3: "Talking Party Identification (TPI)";
- EN 300 392-11-4: "Call Forwarding (CF)";
- ETS 300 392-11-5: "List Search Call (LSC)";
- ETS 300 392-11-6: "Call Authorized by Dispatcher (CAD)";
- ETS 300 392-11-7: "Short Number Addressing (SNA)";
- EN 300 392-11-8: "Area Selection (AS)";
- ETS 300 392-11-9: "Access Priority (AP)";
- EN 300 392-11-10: "Priority Call (PC)";
- ETS 300 392-11-11: "Call Waiting (CW)";
- EN 300 392-11-12: "Call Hold (CH)";**
- EN 300 392-11-12: "Call Hold (CH)";
- ETS 300 392-11-13: "Call Completion to Busy Subscriber (CCBS)";

- EN 300 392-11-14: "Late Entry (LE)";
- ETS 300 392-11-16: "Pre-emptive Priority Call (PPC)";
- EN 300 392-11-17: "Include Call (IC)";
- EN 300 392-11-18: "Barring of Outgoing Calls (BOC)";
- EN 300 392-11-19: "Barring of Incoming Calls (BIC)";
- ETS 300 392-11-20: "Discreet Listening (DL)";
- EN 300 392-11-21: "Ambience Listening (AL)";
- ETS 300 392-11-22: "Dynamic Group Number Assignment (DGNA)";
- ETS 300 392-11-23: "Call Completion on No Reply (CCNR)";
- ETS 300 392-11-24: "Call Retention (CRT)";
- EN 300 392-12: "Supplementary services stage 3";
- ETS 300 392-13: "SDL model of the Air Interface (AI)";
- ETS 300 392-14: "Protocol Implementation Conformance Statement (PICS) proforma specification";
- TS 100 392-15: "TETRA frequency bands, duplex spacings and channel numbering";
- TS 100 392-16: "Network Performance Metrics";
- TS 100 392-17: "TETRA V+D and DMO Release 1.1 specifications".

Proposed national transposition dates	
Date of latest announcement of this EN (doa):	31 August 2003
Date of latest publication of new National Standard or endorsement of this EN (dop/e):	29 February 2004
Date of withdrawal of any conflicting National Standard (dow):	29 February 2004

1 Scope

The present document specifies the stage 2 description of the Supplementary Service Call Hold (SS-HOLD) for the Terrestrial Trunked Radio (TETRA).

SS-HOLD enables a user to interrupt communication on an existing call and then subsequently, if desired, re-establish communication.

Man-Machine Interface (MMI) and charging principles are outside of the scope of the present document.

Supplementary service specifications are produced in three stages according to the method defined in ITU-T Recommendation I.130 [1]. The stage 2 description identifies the functional capabilities and the information flows needed to support the supplementary service as specified in its stage 1 description (see EN 300 392-10-12 [7]). The stage 2 description is followed by the stage 3 description, which specifies the protocols at the air interface and at the various Inter-System Interfaces (ISI) to support the service.

The present document is applicable to TETRA Voice plus Data terminal equipment and networks.

2 References

The following documents contain provisions which, through reference in this text, constitute provisions of the present document.

- References are either specific (identified by date of publication and/or edition number or version number) or non-specific.
- For a specific reference, subsequent revisions do not apply.
- For a non-specific reference, the latest version applies.

Referenced documents which are not found to be publicly available in the expected location might be found at <http://docbox.etsi.org/Reference>.

- [1] ITU-T Recommendation I.130: "Method for the characterization of telecommunication services supported by an ISDN and network capabilities of an ISDN".
- [2] ETSI EN 300 392-1: "Terrestrial Trunked Radio (TETRA); Voice plus Data (V+D); Part 1: General network design".
- [3] ETSI EN 300 392-2: "Terrestrial Trunked Radio (TETRA); Voice plus Data (V+D); Part 2: Air Interface (AI)".
- [4] ETSI EN 300 392-3-2: "Terrestrial Trunked Radio (TETRA); Voice plus Data (V+D); Part 3: Interworking at the Inter-System Interface (ISI); Sub-part 2: Additional Network Feature Individual Call (ANF-ISIIC)".
- [5] ETSI ETS 300 392-3-5: "Terrestrial Trunked Radio (TETRA); Voice plus Data (V+D); Part 3: Interworking at the Inter-System Interface (ISI); Sub-part 5: Additional Network Feature for Mobility Management (ANF-ISIMM)".
- [6] ETSI EN 300 392-9: "Terrestrial Trunked Radio (TETRA); Voice plus Data (V+D); Part 9: General requirements for supplementary services".
- [7] ETSI EN 300 392-10-12: "Terrestrial Trunked Radio (TETRA); Voice plus Data (V+D); Part 10: Supplementary services stage 1; Sub-part 12: Call Hold (CH)".
- [8] ETSI EN 300 392-12-12: "Terrestrial Trunked Radio (TETRA); Voice plus Data (V+D); Part 12: Supplementary services stage 3; Sub-part 12: Call Hold (CH)".

- [9] ISO/IEC 11574 (1994): "Information technology - Telecommunications and information exchange between systems - Private Integrated Services Network - Circuit-mode 64 kbit/s bearer services - Service description, functional capabilities and information flows".

3 Definitions and abbreviations

3.1 Definitions

For the purposes of the present document, the terms and definitions given in EN 300 392-9 [6] apply with the following modifications:

affected user: other party than the served user in an individual call

served user: user participating in an individual call who invokes the supplementary service

NOTE: When the served user has many calls on hold, he may be the calling party for some of them and the connected party for the others.

3.2 Abbreviations

For the purposes of the present document, the following abbreviations apply:

ANF-ISIMM	Additional Network Feature - Inter-System Interface Mobility Management
CC	Basic Service Call Control functional entity
CCA	Basic Service Call Control functional entity agent

NOTE: CC and CCA are applied as defined in ISO/IEC 11574 [9].

FE	Functional Entity
GTSI	Group TETRA Subscriber Identity
HOLD	Call Hold
ISI	Inter-System Interface
ITSI	Individual TETRA Subscriber Identity
LS	Line Station
MS	Mobile Station
PISN	Private Intergrated Services Network
SDL	Specification and Description Language
SS	Supplementary Service

NOTE: The abbreviation SS is only used when referring to a specific supplementary service (e.g. SS-HOLD).

SwMI	Switching and Management Infrastructure
TNSS-SAP	TETRA Network Layer Supplementary Services-Service Access Point

4 Functional model

4.1 Functional model description

The functional model shall comprise the following Functional Entities (FEs):

FE1	Served user functional entity
FE21	Served user SwMI FE
FE21'	Served user new SwMI FE
FE25	Affected user SwMI FE
FE5	Affected user FE

The following relationships shall exist:

ra	between FE1 and FE21
rb	between FE21 and FE5+
rc	between FE21 and FE25
rd	between FE21 and FE21'

Figure 1 shows these FEs and relationships for the basic operational part of SS-HOLD, when the served user does not change location after he has put a (individual) call on hold.

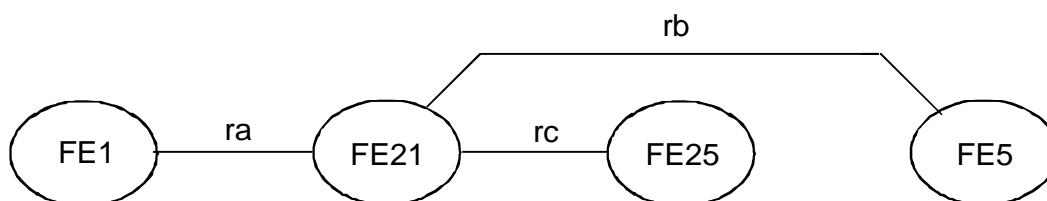

Figure 1: Functional model for the basic operational part of SS-HOLD

Figure 2 shows these FEs and relationships for the operational part of SS-HOLD, when the served user changes location after he has put a (individual) call on hold.

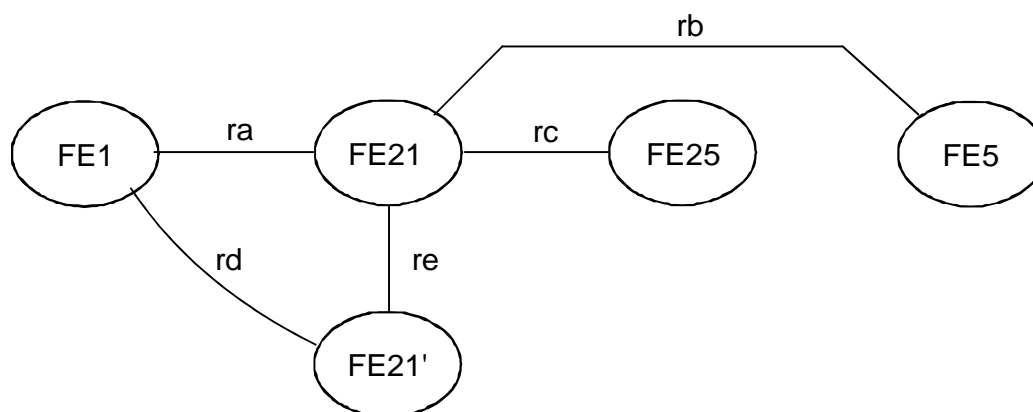

Figure 2: Functional model for the operational part of SS-HOLD with location change of the served user

NOTE: Both figures 1 and 2 apply only in the case of individual call since SS-HOLD does not apply to group call.

4.2 Description of functional entities

4.2.1 Served user functional entity, FE1

FE1 is the functional entity that serves the calling user for the invocation of SS-HOLD.

If the served user changes location with one or more individual call still on hold, FE1 may be informed by FE21' about possible changes for those calls. It will process that information according to its contents; notably if it indicates a call reference change for some calls on hold, it will update accordingly its call references for those calls.

FE1 may also relay the interrogation requests received from the served user to FE21, and the corresponding responses from FE21 to the served user (as indication primitives).

4.2.2 Served user SwMI functional entity, FE21

When it receives a SS-HOLD invocation from FE1, FE21 checks whether SS-HOLD has been activated (i.e. subscribed) and, if so, puts the call on hold, in informing FE5 and FE25.

If the served user changes location with an individual call still on hold, FE21 may attempt to create FE21'. If that attempt is successful, FE21 passes the data about that call to FE21'. If not, it informs the collocated individual call control entity about the situation.

4.2.3 Served user new SwMI functional entity, FE21'

If the served user changes location with a call still on hold, FE21' may be created.

FE21' then receives the data about that call, informs FE1 about the calls on hold for which one of the two following changes has occurred due to the location change: call reference changed or call lost. After that FE21' replaces FE21.

4.2.4 Affected user SwMI functional entity, FE25

FE25 receives from FE21 the information that SS-HOLD has been invoked (by the served user) for the call and passes it to the collocated individual call control entity.

4.2.5 Affected user functional entity, FE5

FE5 is the functional entity that serves the affected user to inform him when the call has been put on hold and then, when it is retrieved.

4.3 Relationship of functional model to basic call functional model

Although no formal models have been defined for basic individual call or for basic group call, those models can be readily derived from the PISN model for basic call, in ISO/IEC 11574 [9].

FE1 shall be collocated with the CCA of the calling user or of the called user in an individual call.

FE21 shall be collocated with the CC functional entity in the served user SwMI in an individual call.

Depending on whether the served user has roamed or migrated (with one or more individual calls on hold), FE21' shall be collocated with the CC functional entity either:

- in the same served user SwMI if the served user has roamed;
- in the served user new SwMI if the served user has migrated.

FE5 shall be collocated with the CCA of the remote party in an individual call.

Figure 3 shows the relationship between the models for SS-HOLD and for the basic individual call.

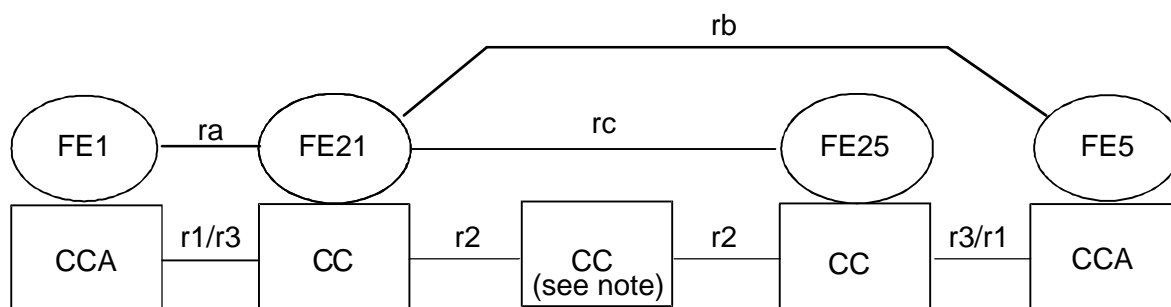

NOTE: It is possible that no intermediate CC be present (i.e. when the called user (whether he is the served user or the/an affected user) is registered in his home SwMI and when no transit Private Integrated (services) Network Exchanges -PINXs- are present).

Figure 3: Relationship between models for SS-HOLD and basic individual call

5 Information flows

5.1 Definition of information flows

In the tables listing the information elements in information flows, the column headed "Type" indicates which of these elements are Mandatory (M), which are Optional (O) and which are Conditional (C).

5.1.1 INFORM 1

INFORM 1 is an unconfirmed information flow:

- across relationship rb from FE21 to FE5 to inform the affected user about the successful result of SS-HOLD invocation;
- across relationship rc from FE21 to FE25 to inform the affected user SwMI about the successful result of SS-HOLD invocation.

There are no elements in that information flow.

5.1.2 INFORM 2

INFORM 2 is an unconfirmed information flow:

- across relationship rb from FE21 to FE5 to inform the affected user about the successful retrieval of the call (previously on hold);
- across relationship rc from FE21 to FE25 to inform the affected user SwMI about the successful the successful retrieval of the call (previously on hold).

There are no elements in that information flow.

5.1.3 INFORM 3

INFORM 3 is an unconfirmed information flow across relationship rb from FE21 to FE5 to inform the affected user that the call on hold is being cleared because the served user has changed location and either the FE21' functional entity cannot be created (e.g. case of migration into a new SwMI that does not support SS-HOLD) or it cannot take over FE21 role to support a later request from the served user (after the change location procedure has been completed) to retrieve the call on hold.

There are no elements in that information flow.

5.1.4 INTERROGATE

INTERROGATE is an unconfirmed information flow across relationship ra from FE1 to FE21 which is used to interrogate the served user SwMI about the calls currently still on hold for the served user.

NOTE: The response/confirmation information flow corresponding to the INTERROGATE request/indication information flow is INTERROGATE ACK (see clause 5.1.5).

There are no elements in that information flow.

5.1.5 INTERROGATE ACK

INTERROGATE ACK is actually the response/confirmation information flow corresponding to the INTERROGATE request/indication information flow. It is thus across relationship ra from FE21 to FE1. It is used to respond to the corresponding interrogation request.

Table 1 lists the elements within the INTERROGATE ACK information flow.

Table 1: Contents of INTERROGATE ACK

Element	Type
Interrogation result	M
Number of calls being on hold	C (see note 1)
Call reference	C (see note 2)
Affected user ITSI	C (see note 2)
Interrogation failure cause	C (see note 3)
NOTE 1: Conditional on the invocation result being positive.	
NOTE 2: Conditional on the invocation result being positive. Shall then be repeated for each call on hold.	
NOTE 3: Conditional on the invocation result being negative.	

The element interrogation result shall indicate whether the corresponding interrogation request has been successful or not.

The element number of calls being on hold shall indicate how many calls are currently still on hold for the served user (i.e. calls previously put on hold by the served user and not retrieved or disconnected).

The element call reference shall identify the call in the served user SwMI.

The element GTSI shall contain the identity of the group of which the call is on hold. The element-affected user ITSI shall indicate the identity of the other party than the served user in an individual call on hold. The ITSI of an individual subscriber is defined in clause 7.2.2 of EN 300 392-1 [2].

The element interrogation failure cause shall indicate the reason why the interrogation request by the served user has failed. That reason may be e.g. because FE21 does not support the interrogation procedure.

5.1.6 INVOKE

INVOKE is an unconfirmed information flow across relationship ra from FE1 to FE21 to invoke SS-HOLD.

NOTE: The response/confirmation information flow corresponding to the INVOKE request/indication information flow is INVOKE ACK (see clause 5.1.7).

There are no elements in that information flow.

5.1.7 INVOKE ACK

INVOKE ACK is actually the response/confirmation information flow corresponding to the INVOKE request/indication information flow. It is thus across relationship ra from FE21 to FE1. It is used to respond to the corresponding invocation.

Table 2 lists the elements within the INVOKE ACK information flow.

Table 2: Contents of INVOKE ACK

Element	Type
Invocation result	M
Invocation failure cause	C (see note)
NOTE: Conditional on the invocation result being negative.	

The element invocation result shall indicate whether the corresponding invocation request by the served user has been successful or not.

The element invocation failure cause shall indicate the reason why the invocation request by the served user has failed. That reason may be e.g. because the maximum number of calls on hold for FE1 has already been reached.

NOTE: The above statement implies that there is a FE21 functional entity. Otherwise by definition there is no INVOKE ACK information flow (since the served user SwMI does not support SS-HOLD). If this is the case, the served user who has invoked SS-HOLD will be informed about it by the generic failure cause defined in EN 300 392-9 [6] clause 11.2.1.

5.1.8 rd_LOCATION CHANGE

rd_LOCATION CHANGE is an unconfirmed information flow across relationship rd from FE21' to FE1 in the case of location change of the served user to allow the later retrieval of the calls still on hold. The support of that information flow is optional for FE21', but mandatory for FE1 (i.e. if FE21' sends that information flow, FE1 has first to receive it, second to act according to its information).

Table 3 lists the elements within the rd_LOCATION CHANGE information flow.

Table 3: Contents of rd_LOCATION CHANGE

Element	Type
Location change procedure support	M
Call reference update	O (see note 1)
Calls lost	O (see note 2)
NOTE 1: If the location change procedure is supported (information given by the element location change procedure support): - may be present in the case of roaming (i.e. FE21' located in the same SwMI as FE21); - shall be present in the case of migration (i.e. FE21' located in another SwMI than FE21). NOTE 2: Shall be present if the location change procedure is supported and if calls have been lost during that procedure (e.g. by lack of resources).	

The element location change procedure support shall indicate whether or not FE21' can take over FE21 role to support a later request from the served user (after the change location procedure has been completed) to retrieve the call on hold.

NOTE: The choice has been made not to consider the case where the call control entity collocated with FE21' would support the procedure for keeping "alive" calls still on hold when the served user has changed location but would not be able to support any later retrieval request for such calls: the reason for that choice is that such FE21' would not have been able to successfully take over FE21 role for the possible later request from the served user to retrieve any of his calls on hold.

The element call reference update shall indicate the new call references when they have changed due to the location change.

The element calls lost shall indicate the calls on hold which have been cleared during the location change procedure.

5.1.9 re_LOCATION CHANGE

re_LOCATION CHANGE is a confirmed information flow across relationship re from FE21 to FE21' in the case of location change of the served user to allow the later retrieval of his calls on hold. The support of that information flow is optional for both FE21 and FE21'.

NOTE 1: re_LOCATION CHANGE is over the Inter-System Interface (ISI) only when the served user changes location in registering in a new SwMI (i.e. according to TETRA terminology, the served user migrates). Otherwise, when the served user changes location within the same SwMI (i.e. according to the TETRA terminology, the served user roams), re_LOCATION CHANGE is internal to that SwMI.

Table 4 defines the content of the re_LOCATION CHANGE request/indication information flow and table 5, that of the re_LOCATION CHANGE response/confirmation information flow.

Table 4: Content of re_LOCATION CHANGE request/indication

Element	Type
Number of calls on hold	M

The element number of calls on hold shall indicate how many calls the served user has still on hold.

Table 5: Content of re_LOCATION CHANGE response/confirmation

Element	Type
Location change support	M

The element location change support shall indicate whether or not FE21' can take over FE21 role to support a later request from the served user (after the change location procedure has been completed) to retrieve the call on hold to which the re_LOCATION CHANGE response/confirmation information flow refers.

NOTE 2: See note in clause 5.1.8.

5.1.10 RETRIEVE

RETRIEVE is an unconfirmed information flow across relationship ra from FE1 to FE21 to request the retrieval of a call on hold.

NOTE: The response/confirmation information flow corresponding to the RETRIEVE request/indication information flow is RETRIEVE ACK (see clause 5.1.11).

Table 6 defines the content of the RETRIEVE information flow.

Table 6: Content of RETRIEVE

Element	Type
Call reference	M

The element call reference shall identify the call to be retrieved.

5.1.11 RETRIEVE ACK

RETRIEVE ACK is actually the response/confirmation information flow corresponding to the RETRIEVE request/indication information flow. It is thus across relationship ra from FE21 to FE1. It is used to respond to the corresponding retrieval request.

Table 7 lists the elements within the RETRIEVE ACK information flow.

Table 7: Contents of RETRIEVE ACK

Element	Type
Call reference	M
Retrieval result	M
Retrieval failure cause	C (see note)
NOTE: Conditional on the retrieval result being negative.	

The element call reference shall identify the call retrieved.

The element retrieval result shall indicate whether the corresponding retrieval request by the served user has been successful or not.

The element invocation failure cause shall indicate the reason why the retrieval request by the served user has failed. That reason may be e.g. because the call has been cleared in the meantime.

5.2 Relationship of information flows to basic call information flows

Table 8 shows the relationship of the SS-HOLD information flows to those of basic call over both the air interface and the intersystem interface (ISI).

NOTE: The basic individual call information flows are defined:

- for the air interface, if not explicitly in EN 300 392-2 [3], at least implicitly in clauses 11 and 14 of the present document; and
- for the ISI, in EN 300 392-3-2 [4].

Table 8: Relationship of SS-HOLD information flows to basic call

Information flow	Independent of basic call?	With basic call?	Basic call flows:
INFORM 1	yes	no	
INFORM 2	yes	yes	ISI-CALL RESTORATION (see note 2)
INFORM 3	no	yes	D-RELEASE (see note 3)
INTERROGATE	yes (see note 1)	no	
INTERROGATE ACK	yes (see note 1)	no	
INVOKE	yes	no	
INVOKE ACK	yes	no	
rd_LOCATION CHANGE	yes (see note 1)	no	
re_LOCATION CHANGE request/indication	no	yes	CALL RESTORE PREPARE request/indication (see note 4)
re_LOCATION CHANGE response/confirmation	no	yes	CALL RESTORE PREPARE response/confirmation (see note 4)
RETRIEVE	yes	no	
RETRIEVE ACK	yes	no	

NOTE 1: This information flow is not only independent of basic call, but call unrelated.

NOTE 2: INFORM 2 is sent together with the (ANF)-ISI(IC)-CALL RESTORATION information flow if the served user retrieves the call on hold after having changed location in registering in a new SwMI (i.e. after having migrated) while the call was on hold.

NOTE 3: In addition if the call is over the ISI (i.e. the terminating SwMI is different from the originating SwMI), INFORM 3 is sent together with the ANF-ISIIC RELEASE information flow.

NOTE 4: The CALL RESTORE PREPARE request/indication and response/confirmation information flows are ISI basic individual call information flows only when the served user changes location in registering in a new SwMI (i.e. the served user migrates). The CALL RESTORE PREPARE request/indication information flow is then sent together with the PISN SETUP request/indication information flow. If that information flow is successful, the corresponding CALL RESTORE PREPARE response/confirmation information flow is sent together with the PISN SETUP response/confirmation information flow (the PISN SETUP response/confirmation information flow translates into the PSS1 CONNECT message in the corresponding protocol). If that information flow is unsuccessful, the corresponding CALL RESTORE PREPARE response/confirmation information flow is sent together with the PISN RELEASE request/indication information flow. When the served user changes location within the same SwMI with a call still on hold (i.e. the served user roams), the CALL RESTORE PREPARE request/indication and response/confirmation information flows remain internal to that SwMI.

5.3 Service primitives

This clause lists SS-HOLD service primitives used to invoke or being a result of information flow sequences. The SS-HOLD service primitives are defined in EN 300 392-12-12 [8] clause 5.4.

The SS-HOLD service primitives for the served user at the MS/LS TNSS-SAP shall be:

- INTERROGATE request;
- INTERROGATE ACK indication;
- INVOKE request;
- INVOKE confirm;
- RETRIEVE request;
- RETRIEVE confirm.

NOTE: There is no LOCATION CHANGE primitive, because the corresponding information flow across relationship rd is not sent to the user application (but only to FE1).

The SS-HOLD service primitives for the affected user at the MS/LS TNSS-SAP shall be:

- INFORM 1 indication;
- INFORM 2 indication;
- INFORM 3 indication.

5.4 Examples of information flow sequences

EN 300 392-12-12 [8], on SS-HOLD stage 3 description, specifies the signalling procedures in support of the information flow sequences specified in the following clauses. In addition, it specifies signalling procedures to cover other sequences arising from error situations, interactions with basic call, interactions with other supplementary services, different topologies etc.

In the figures, SS-HOLD information flows are represented by solid arrows and basic call information flows are represented by broken arrows. An ellipse embracing two information flows indicates that the two information flows occur together. Within a column representing an SS-HOLD functional entity, the numbers refer to functional entity actions listed in clause 6.

5.4.1 Interrogation

Figure 4 shows the information flow sequence for the normal operation of SS-HOLD interrogation.

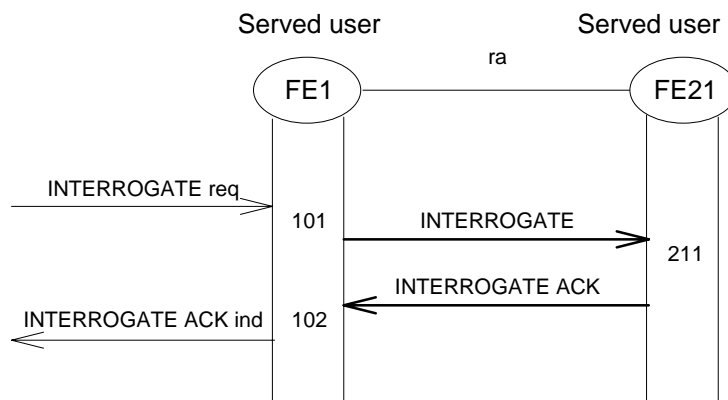

Figure 4: Interrogation of SS-HOLD

5.4.2 Invocation and operation

5.4.2.1 Successful invocation

Figure 5 shows the information flow sequence for the successful SS-HOLD invocation (during an individual call).

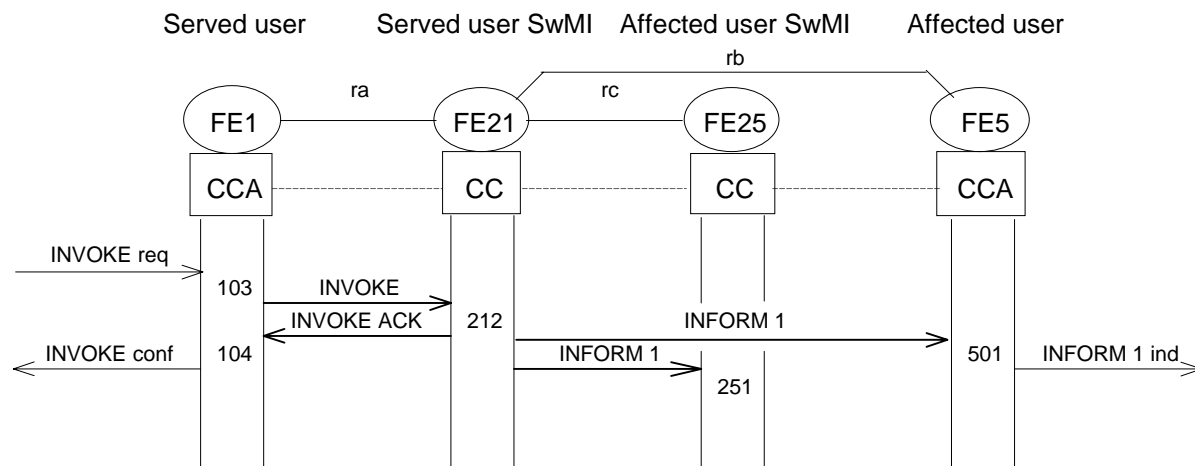
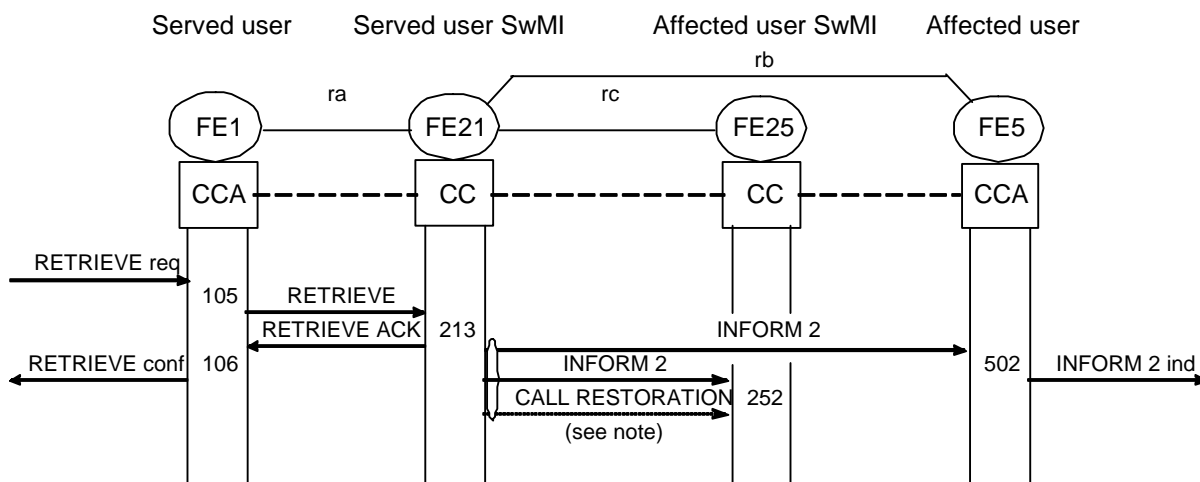

Figure 5: Successful invocation

5.4.2.2 Successful retrieval of call on hold

Figure 6 shows the information flow sequence for the successful retrieval of a (individual) call previously put on hold.



NOTE: INFORM 2 is sent together with ANF-ISIIC-CALL RESTORATION only if the served user has migrated since he has (successfully) invoked SS-HOLD and if relationship rc is across the ISI (i.e. the present served user SwMI is different from both the old one and the affected user SwMI).

Figure 6: Successful retrieval of a call put on hold

5.4.2.3 Invocation failure

Figure 7 shows the information flow sequence when SS-HOLD invocation fails.

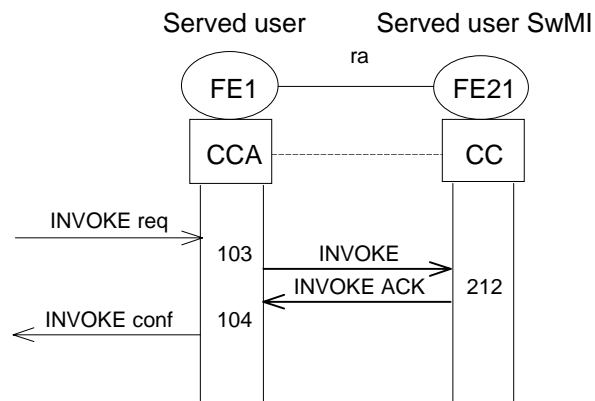

Figure 7: Invocation failure

5.4.2.4 Retrieval failure

Figure 8 shows the information flow sequence when the request by the served user to retrieve a call previously put on hold fails.

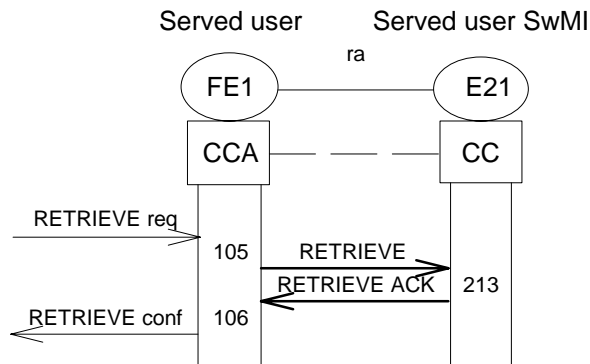

Figure 8: Retrieval failure

5.4.2.5 Migration of served user with calls on hold

Figure 9 shows the information flow sequence for the successful migration of the served user with one or more (individual) calls on hold.

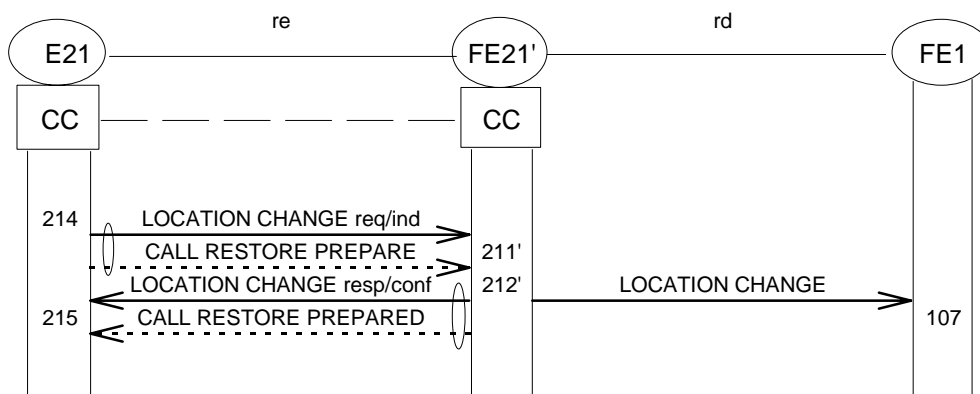

Figure 9: Successful migration of served user with calls on hold

Figure 10 shows the information flow sequence for the unsuccessful migration of the served user with one or more (individual) calls on hold.

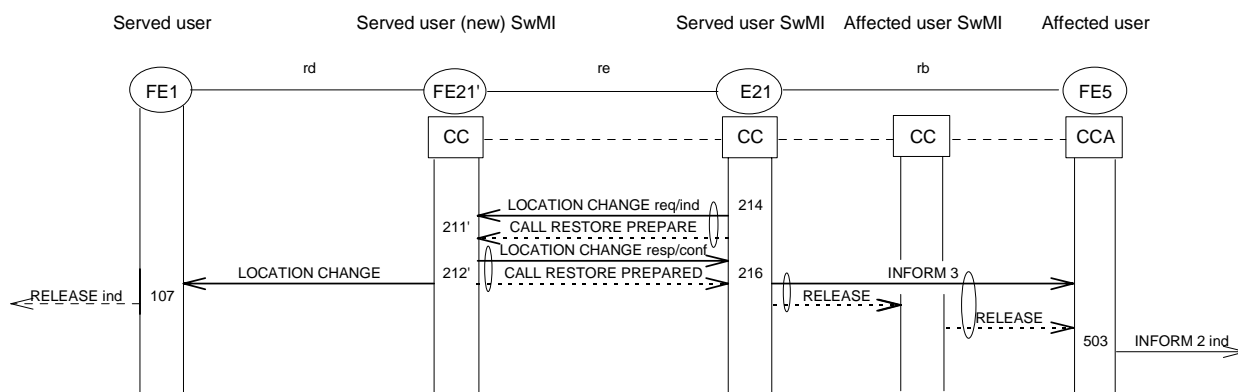

Figure 10: Unsuccessful migration of served user with calls on hold

6 FE actions

These functional entity actions cover items presented in the previous scenarios. There may be other actions due to exceptional cases.

6.1 Functional Entity actions of FE1

- 101 Receive the user application request for interrogation and send to FE21 the corresponding INTERROGATE request/indication information flow.
- 102 Receive the INTERROGATE ACK request/indication information from FE21 and deliver its information to the user application.
- 103 Receive the SS-HOLD invocation request from the user application and send to FE21 the corresponding INVOKE request/indication information flow. Start the invocation timer and wait for receiving the acknowledging INVOKE ACK request/indication information flow from FE21.
If the invocation timer expires before (the INVOKE ACK request/indication information flow has been received), consider that SS-HOLD invocation has failed. Possibly send again the INVOKE request/indication information flow.
- 104 Receive the INVOKE ACK request/indication information flow from FE21 and pass its information to the user application (about the success of the previous SS-HOLD invocation or its failure, with the reason in case of failure).
- 105 Receive the request to retrieve a call on hold from the user application and send to FE21 the corresponding RETRIEVE request/indication information flow. Start the retrieval timer and wait for receiving the acknowledging RETRIEVE ACK request/indication information flow from FE21.
If the retrieval timer expires before (the RETRIEVE ACK request/indication information flow has been received), consider that the attempt to retrieve the call on hold has failed. Then either send again the RETRIEVE request/indication information flow attempt or clear the call on hold.
If the served user has changed location after having sent the RETRIEVE request/indication information flow and has not received the acknowledging RETRIEVE ACK request/indication information flow, send again the RETRIEVE request/indication information flow after having completed action 107.
- 106 Receive the RETRIEVE ACK request/indication information flow from FE21 and pass its information to the user application (about the success of the previous retrieval request or its failure, with the reason in case of failure).
- 107 Whenever the served user changes location (i.e. roams or migrates), start the call identifier change timer and wait for the rd_LOCATION CHANGE request/indication information flow from FE21'.
If the call identifier change timer expires before (the rd_LOCATION CHANGE request/indication information flow has been received), consider that the call reference is still the same (i.e. it has not changed as a result of the change request).
Receive the rd_LOCATION CHANGE response/confirmation information flow from FE21' and update accordingly the call references of the calls on hold and/or clear the calls on hold lost during the location change process.

6.2 Functional Entity actions of FE21

- 211 On receipt of INTERROGATE request/indication information flow, verify that SS-HOLD has been subscribed to for the served user. If yes, fetch the information about the calls put on hold by the served user and not yet retrieved or cleared and send it in the INTERROGATE ACK information flow to FE1. If not, return an error indication to FE1.
- 212 On receipt of the INVOKE request/indication information flow from FE1, check if SS-HOLD has been activated (i.e. subscribed to) and if the maximum number of calls put on hold by the served user and not yet retrieved or cleared has not already been reached.
Whether the result of the served user invocation request is positive or negative, inform the served user about it in sending to FE1 the INVOKE ACK request/indication information flow.
If that result is positive, put the call on hold and inform both the affected user and the affected user SwMI about the situation in sending to FE5 and FE25 the INFORM 1 request/indication information flow.
- 213 On receipt of the RETRIEVE request/indication information flow from FE1, check if the call reference in that information flow is that of a call previously put on hold by the served user and not yet retrieved or cleared.
If that result is positive:
- re-establish the call to the served user and inform him about that in sending to FE1 the RETRIEVE ACK request/indication information flow; and
- send the INFORM 2 request/indication information flow to both FE5 and FE25. If the served user has migrated since he has (successfully) invoked SS-HOLD and if relationship rc is across the ISI (i.e. the present served user SwMI is different from both the old one and the affected user SwMI) -and only then- send INFORM 2 to FE25 together with ANF-ISIIC-CALL RESTORATION.
If the result is negative, inform the served user about it in sending to FE1 the RETRIEVE ACK request/indication information flow.
- 214 When informed that the served user has changed location, optionally request the collocated ANF-ISIIC control entity to send the ANF-ISIIC-CALL RESTORE request/indication information flow for each call still on hold and send to FE21' together with this information flow the re_LOCATION CHANGE request/indication information flow. Then wait for receiving the corresponding re_LOCATION CHANGE response/confirmation information flow from FE21'.
- 215 Receive the corresponding re_LOCATION CHANGE response/confirmation information flow from FE21'.
If it indicates that the call control entity collocated with FE21' can take over FE21 role to support a later request from the served user (after the change location procedure has been completed) to retrieve the call on hold to which the re_LOCATION CHANGE information flows refers, instruct the collocated ANF-ISIIC control entity to operate as if the call had been restored (in cutting through the user information channel, i.e. the traffic channel, by forward switching).
- 216 If either FE21 does not support the SS-HOLD location change procedure or the re_LOCATION CHANGE response/confirmation information flow (from FE21') indicates that the call control entity with which FE21' is collocated cannot take over FE21 role to support a later request from the served user (after the change location procedure has been completed) to retrieve the call on hold to which it refers, clear the call in sending the INFORM 3 request/indication information flow to FE5.
Do the same if the ANF-ISIIC timer for receiving the ANF-ISIIC-CALL RESTORE PREPARE response/confirmation information flow with which the response to the re_LOCATION CHANGE request/indication information flow request/indication information flow is to be received (see table 8) has expired and that ANF-ISIIC-CALL RESTORE PREPARE response/confirmation information flow has not been received yet.

6.3 Functional Entity actions of FE21'

- 211' Receive a first re_LOCATION CHANGE request/indication information flow from FE21. Respond in sending the corresponding re_LOCATION CHANGE response/confirmation information flow. Wait re_LOCATION CHANGE request/indication information flow for all calls on hold (for the served user) in starting timer Tloc_change.
- 212' Either when having received the re_LOCATION CHANGE request/indication information flows for all calls on hold (for the served user), or upon expiry of timer Tloc_change, send the rd_LOCATION CHANGE information flow to FE21.
Take over FE21 role for each call on hold for which it has received the re_LOCATION CHANGE request/indication information flow and answered it in indicating in the corresponding re_LOCATION CHANGE response/confirmation information flow that it can take over FE21 role to support a later request from the served user (after the change location procedure has been completed) to retrieve the call on hold.

NOTE: See notes in clause 5.1.8.

6.4 Functional Entity actions of FE25

- 251 Receive the INFORM 1 request/indication information flow from FE21 and pass its information to the collocated individual call control entity (i.e. that the served user has invoked SS-HOLD for the call).

NOTE 1: That collocated individual call control entity may use that information to save radio resources at the affected user MS air interface as long the call is on hold.

- 252 Receive the INFORM 2 request/indication information flow from FE21 and pass its information to the collocated individual call control entity (i.e. that the served user has retrieved the call on hold).

NOTE 2: If that collocated individual call control entity had used the information that the call had been put on hold to save radio resources at the affected user MS air interface (see note 1), it will then re-allocate the necessary radio resource.

6.5 Functional Entity actions of FE5

- 501 Receive the INFORM 1 request/indication information flow from FE21 and pass its information to the user application (i.e. that the call in which the affected user participates has just been put on hold).
- 502 Receive the INFORM 2 request/indication information flow from FE21 and pass its information to the user application (i.e. that the call in which the affected user participates and which was previously on hold has just been retrieved).
- 503 Receive the INFORM 3 request/indication information flow from FE21 and pass its information to the user application (i.e. that the call in which the affected user participates and which was previously on hold is cleared because the optional SS-HOLD procedure of location change of the served user is not supported by FE21 or by FE21').

7 Allocation of functional entities to physical equipment

The allocations of functional entities to SwMIs and MS/LSs shall be as shown in table 9.

Table 9: Scenarios for the allocation of FEs to physical equipment/SwMI and MS/LSs

	FE1	FE21	FE21'	FE25	FE5
Scenario 1	Calling user MS/LS	Originating SwMI	-	Terminating SwMI	Connected user MS/LS
Scenario 2	Connected user MS/LS	Terminating SwMI	-	Originating SwMI	Calling user MS/LS
Scenario 3	Calling user MS	Originating SwMI	Same originating SwMI (see note 1)	Terminating SwMI	Connected user MS
Scenario 4	Connected user MS	Terminating SwMI	Same terminating SwMI (see note 1)	Originating SwMI	Calling user MS
Scenario 5	Calling user MS	Originating SwMI	New originating SwMI (see note 2)	Terminating SwMI	Connected user MS
Scenario 6	Connected user MS	Terminating SwMI	New terminating SwMI (see note 2)	Originating SwMI	Calling user MS
Scenario 7	Calling user MS	Originating SwMI	-	Outgoing gateway	External connected user
Scenario 8	Connected user MS/LS	Terminating SwMI	-	Incoming gateway	External calling user
Scenario 9	Calling user MS	Originating SwMI	Same originating SwMI (see note 2)	Outgoing gateway	External connected user
Scenario 10	Connected user MS	Terminating SwMI	Same terminating SwMI (see note 1)	Incoming gateway	External calling user
Scenario 11	Calling user MS	Originating SwMI	New originating SwMI (see note 2)	Outgoing gateway	External connected user
Scenario 12	Connected user MS	Terminating SwMI	New terminating SwMI (see note 2)	Incoming gateway	External calling user
Scenario 13	External calling user	Incoming gateway	-	Originating SwMI	Calling user MS/LS
Scenario 14	External connected user	Outgoing gateway	-	Originating SwMI	Calling user MS/LS
NOTE 1: Case of roaming, i.e. within the same SwMI, and where that SwMI supports the SS-HOLD location change procedure.					
NOTE 2: Case of migration, i.e. into a new SwMI, and where that SwMI supports the SS-HOLD location change procedure.					

8 Interworking considerations

The case where SS-HOLD extends to several TETRA networks has already been taken into account in the preceding clauses, except for the exchange of information related to the support and the subscription of SS-HOLD. Such exchange occurs when a subscriber migrates into a SwMI different from his home SwMI.

As defined in ETS 300 392-3-5 [5], such exchange is ensured by the ANF-ISIMM PROFILE UPDATE request/indication information flow, which contains the information whether SS-HOLD has been subscribed to for the subscriber (which implies that SS-HOLD is supported by the concerned MS). If so, the corresponding ANF-ISIMM PROFILE UPDATE response/confirmation information flow contains the information whether SS-HOLD is supported by the visited SwMI.

In the case of a call with an external user, SS-HOLD shall apply as specified for calls between TETRA users, except that for the information flows INFORM 1, 2 and 3 which cannot be extended to the external user by the external network. In that case, FE5 shall be allocated to the gateway with the external network for the corresponding INFORM information flows.

If the call hold supplementary service is available to the external user in the other network, and if that user invokes it during an individual call with a TETRA user, the TETRA gateway may extend the INFORM information flows for that external supplementary services to the TETRA user in translating those information flows into the TETRA SS-HOLD INFORM 1, 2 or 3.

History

Document history		
V1.1.1	January 2001	Publication
V1.1.2	May 2003	Publication